

IMPORTANT: Please read these instructions carefully. Whilst straightforward, the installation of these devices is critical to their performance. Installation must be performed by a suitably qualified person in accordance with applicable standards.

1. Introduction

1.1 These user instructions apply to the Novaris intrinsically safe range of slimline signal line protectors.

Cat No. (module only):

IS-SL7v5	IS-SL-iSwitch	IS-SSP6A-14
IS-SL18	IS-SL-485	IS-SSP6A-26
IS-SL36	IS-SL-DH	IS-SSP6A-38
IS-SL-PSTN	IS-SL-RTD	

Cat No. (base only):

IS-SLDIN-G	IS-SLDIN-EC90	IS-SLDIN-I
------------	---------------	------------

1.2 These products are multistage signal line protectors that protect against the effects of lightning induced surges and other transient overvoltages. They provide both common-mode and transverse-mode protection, which is essential for the effective protection of any system.

1.3 These products are intrinsically safe (IS) approved. Therefore, the plug-in modules must only be used with a corresponding IS approved base and visa-versa.

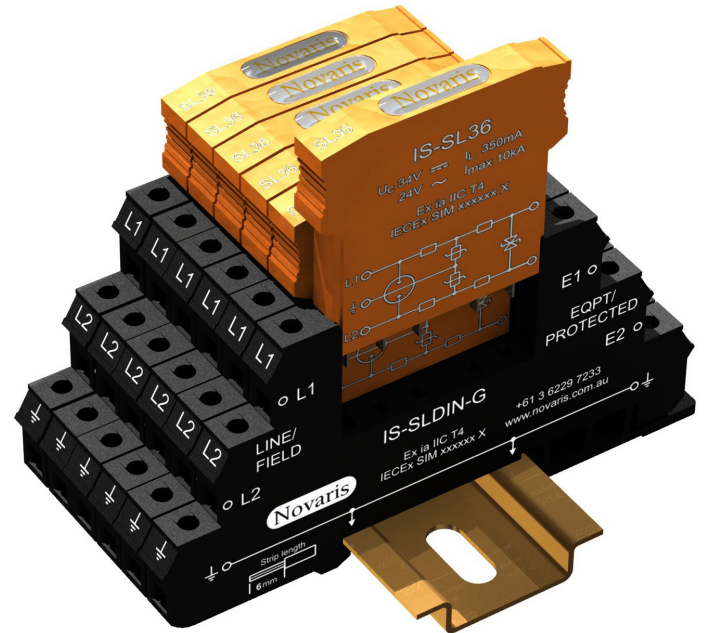

Figure 1: Novaris Slimline signal line protectors

2. Before Installation

- 2.1 Ensure that the maximum operating voltage of the signal line does not exceed the clamping voltage of the signal line protector as described in the specifications.
- 2.2 Ensure that the operating current of the signal line does not exceed the maximum load rating as described in the specifications.
- 2.3 If isolation between the earth terminals and the DIN rail is required, yet must be connected during a transient overvoltage, use the SLDIN-EC90 base. If total isolation is required use the SLDIN-I base.

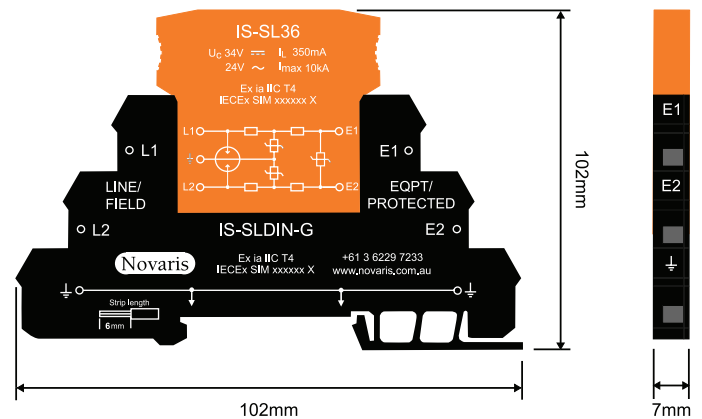

Figure 2: Dimensions of Slimline signal line protectors

3. Installation

- 3.1 **Point of Connection:** The surge protector should be connected at the closest practical point to the equipment to be protected.
- 3.2 **Mounting:** Slimline signal line protectors are most easily and effectively mounted on DIN rail using their integral clip. This also provides an excellent earth connection (provided the DIN rail is properly earthed).

If the unit is to be positioned in an exposed environment it should be mounted in an enclosure. Suitable polycarbonate enclosures are available from Novaris.

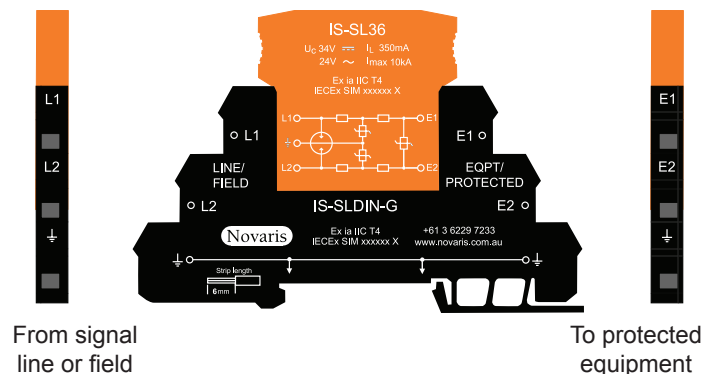

Figure 3: Signal line protectors are connected in series

3.3 Isolation: This device must be galvanically isolated using a suitable safety barrier.

3.4 Wiring: Incorrect installation of surge protection devices (SPDs) can render them ineffective. The Novaris slimline signal line protectors connect in line (Figure 3). These should be located as close as possible to the equipment requiring protection.

3.5 Earthing: Earthing is important. Normally the DIN rail provides a low impedance earth connection to the frame. Where connection to a separate earth bar is required, wire this from the LINE/FIELD earth connection. Choose the most suitable base configuration to suit your application.

Figure 4 shows an incorrect wiring scheme where the transient voltage developed across the earth lead inductance directly adds to the common mode let through voltage of the SPD. This will appear across the terminals of the protected equipment and if sufficiently high could cause damage - despite the presence of the SPD.

Figure 5 shows the correct installation scheme. The earth reference from the protected equipment must connect to the EQPT/PROTECTED earth terminal of the SPD.

IMPORTANT: Because the earth is shunt-connected, the inductance of the connection has a significant effect on performance. Most importantly, **the length of the earth connection must be kept as short as possible**. This is not the case with the other connections because they are series-connected.

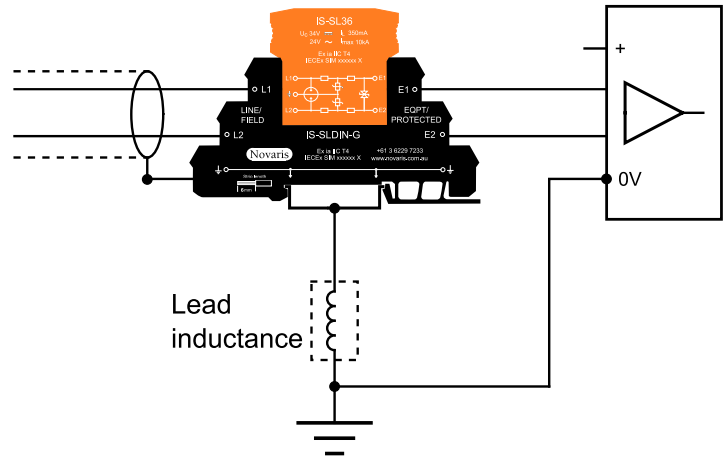

Figure 4: Incorrect installation scheme

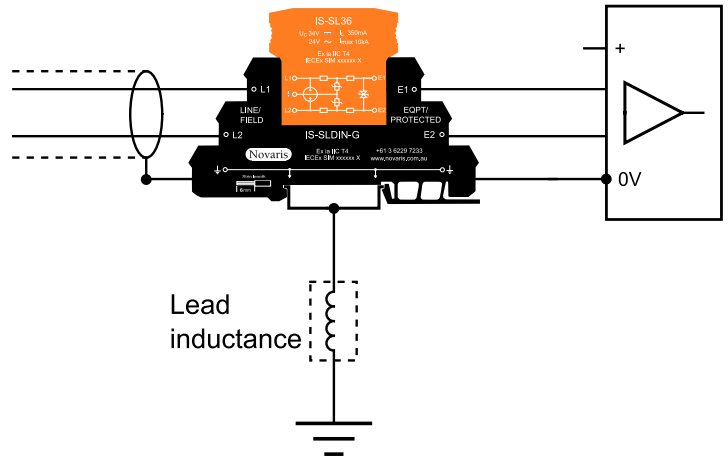

Figure 5: Correct installation scheme

4. After Installation

- 4.1 Check the installation by testing that the equipment is still operating correctly.
- 4.2 Novaris slimline signal line protectors are extremely robust and require very little maintenance. They feature failsafe overcurrent fusing. In the event of a surge that is large enough to damage the surge protection components, the fuses will operate. This is easily detectable as the signal will no longer pass. Under these circumstances the signal line protector should be replaced as soon as possible.
- 4.3 Novaris slimline signal line protectors contain no user servicable parts and must be replaced with genuine Novaris modules.

5. Hazardous Area Application

- 5.1 Field instrument protection should take place in Zone 1 and as close as practically possible to the Zone 0 boundary, preferably within one meter to prevent transient voltages from entering Zone 0. Ideally, the surge protector should be installed within the housing of the field instrument, however due to space restrictions it may be necessary to mount the unit in a suitable enclosure available from Novaris.
- 5.2 Figure 6 shows a typical hazardous area installation where the body of the field instrument is earthed through the metallic pipework. In this instance it is important to earth the Novaris slimline signal line protector to the instrument body. This connection **MUST** be as short as practically possible.

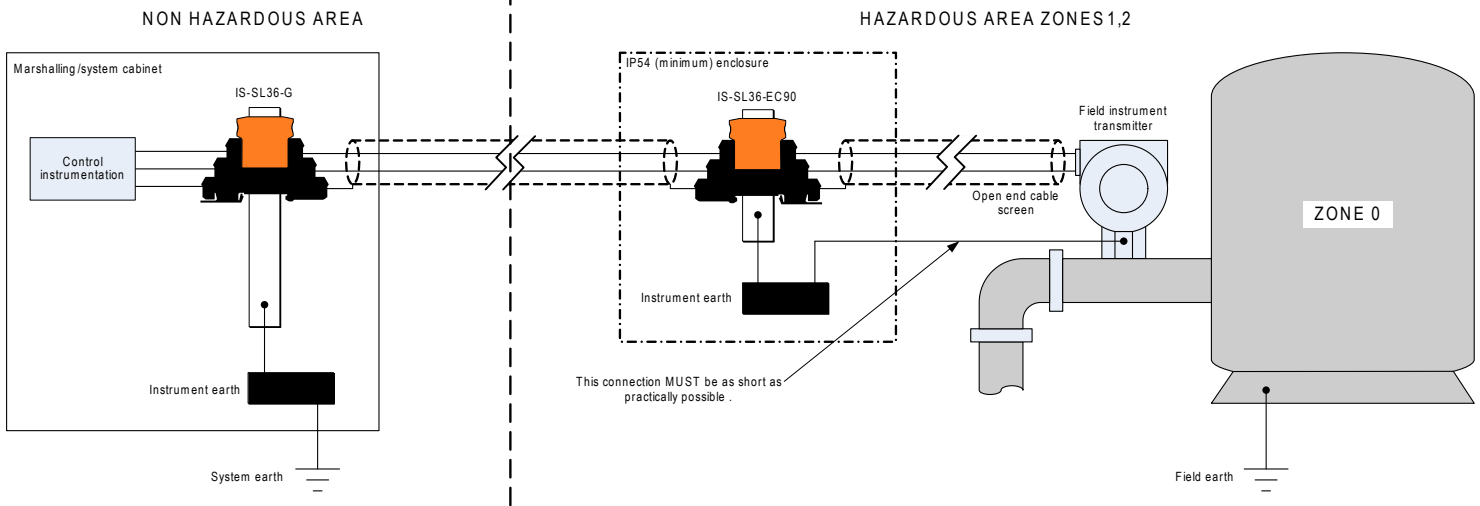

Figure 6: Typical hazardous area installation where field instrument body is earthed through pipework.

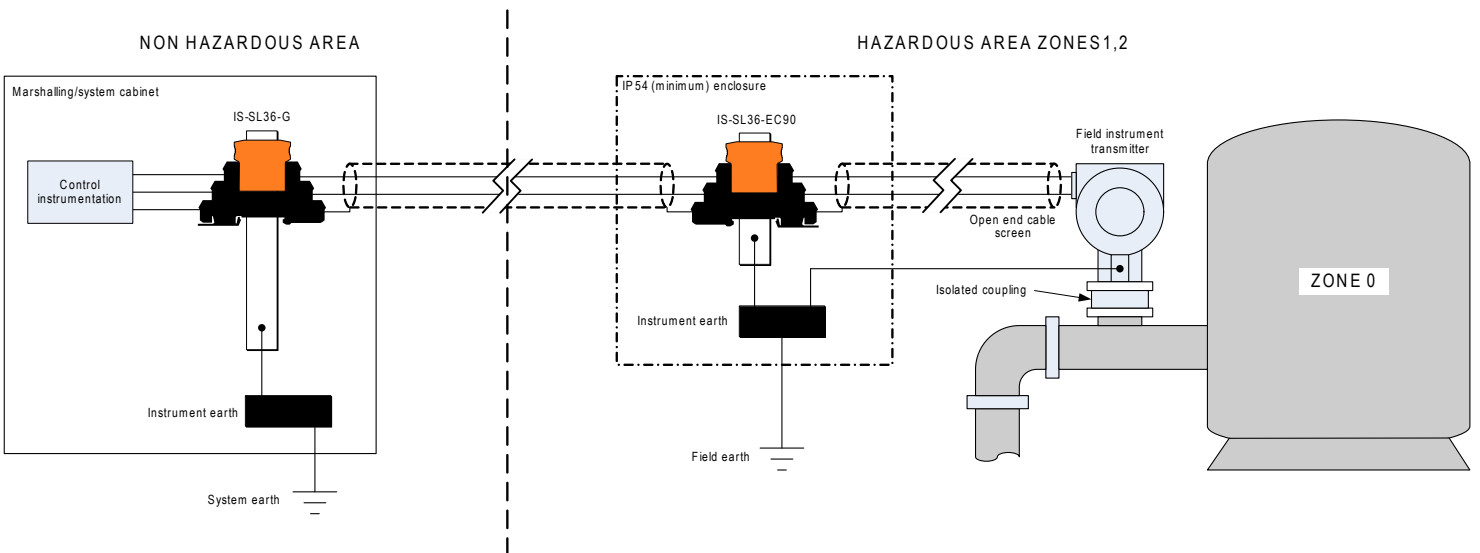

Figure 7: Typical hazardous area installation where field instrument body is isolated from pipework.

5.3 Figure 7 shows a typical hazardous area installation where the body of the field instrument is isolated from the pipework. In this case the Novaris slimline signal line protector and the field instrument body must be earthed at a common point, typically an earth bar.

6. Specifications

		IS-SL7V5	IS-SL18	IS-SL36	IS-SL-PSTN	IS-SL-iSwitch	IS-SL-485	IS-SL-DH	IS-SL-RTD	SSP6A-14-G	SSP6A-28-G	SSP6A-38-G	IS-SLDIN-EC90	
Electrical Specifications:														
Connection Type		Series											-	
Modes of protection		Transverse and common mode											-	
Maximum continuous voltage (DC)	U_c	7V	16V	34V	200V	200V	8V	34V	7V	14V	28V	34V	-	
Maximum continuous voltage (AC)	U_c	5V	11V	24V	140V	140V	6V	24V	5V	11V	20V	30V	-	
Maximum discharge current (8/20 μ s)	I_{max}	5kA									9.6kA			-
Maximum load current	I_L	350mA			180mA	500mA			350mA	6A			-	
Voltage protection level @ 5kV (10/700 μ s)	U_p	8V	19V	40V	235V	30V	15V	50V	8V	26V	52V	70V	-	
Line resistance		8.2 Ω	8.2 Ω	8.2 Ω	8.2 Ω	17 Ω	3.9 Ω	3.9 Ω	3.9 Ω	0 Ω			-	
3dB Frequency @ 50 Ω	f_c	250kHz	250kHz	250kHz	10MHz	20MHz	20MHz	20MHz	250kHz	100kHz	100kHz	100kHz	-	

Safety Parameters:													
	U_i	30V			17.2V	30V	24V			30V			30V
	I_i	0.639A			1.639A	1.639A	0.157A			1.639A			3A
	P_i	1.348W			0.68W	1.3W	1.347W			2.2W			2.4W
	C_i	0			202nF	0	0			0			0
	L_i	0			0	0	72.6 μ H			0			0

Mechanical Specifications:													
Operating temperature range		-20°C to 40°C											
Operating humidity		0 to 90%											
Terminal capacity		2.5mm ²											
Terminal screw torque		0.5Nm											
Environmental		IP 20											
Mounting		TS35 DIN rail											
Weight		35g											

7. Standards Compliance

Ex ia IIC T4 IP20
 ITU(CCITT) IX K17
 AS1768:2007
 BS6651:1999
 CP33:1996
 IEEE C62.41:2002
 IEC 61643-21
 UL497B
 N2530 (IS-SL-PSTN only)

8. Warnings

WARNING: These devices present a potential electrostatic charging hazard.