

Novaris[®]

PART OF THE POWERCOM GROUP

EKIT Cable Bonding Kit

Installation Instructions



Thank you for choosing Novaris surge protection.

Novaris has been designing and manufacturing lightning and electrical disturbance protection for over 15 years. We specialise in the protection of power and data signalling. Our products are in use Australia wide, and internationally, and we are now world leaders in lightning and surge technology.

At our Australian headquarters we operate a full time research and development group, employing professional engineers, technical officers and drafting support staff. Our testing laboratory is capable of generating and measuring simulated lightning impulses in accordance with world power and telecommunications standards. We also have offices and distributors throughout Australia and world wide.

Novaris designs and manufactures all the products bought by you at our manufacturing locations under the ISO 9001:2000 quality assurance system. Giving you the reassurance that your surge protection will protect your equipment.

We guarantee the quality of our products.

We stand by our products for their quality, and ingenuity. If there are any improvements you feel can make on our products, please call us, email us, or visit us. Our engineering sales team are always keen to hear from our customers.

If you require further information about our company or have a suggestion to change this product to suit your need better,

Please call us on: (+613) 6229 7233
Or email us on: info@novaris.com.au
Include in the subject line: "product improvement"

IMPORTANT: Please read these instructions carefully. Whilst straightforward, the installation of these devices is critical to their performance. Installation should only be carried out by a suitably qualified person in accordance with all relevant standards.

Earth Kit Contains:

- 1 x earthing kit body with contacting surface incl Butyl sealing compound and earthing wire
- 1 or 2 x screws depending on kit size (M6 Din 912)



Step 1: Preparation

Note: Ensure that the cable to which the earth kit is to be attached is straight!

Figure 1a: Prepare earthing kit ready for installation.

Figure 1b: Clean the plastic jacket at the desired earthing point and cut out a suitably wide strip of the sheath.

For EKIT-012, a suitably wide strip is 15mm, for EKIT-078 and EKIT-158 a suitably wide strip is 20mm.

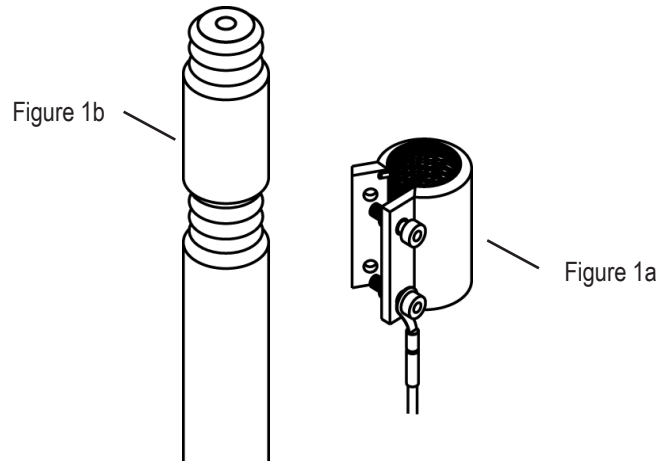

Step 2: Installation

The earth kit should be installed in such a way that the earth lead, from body to lug is pointing in the direction current would flow in the event of a lightning strike (ie towards earth).

Remove covering paper from butyl sealing compound. Wrap the ground kit body around the cable and physically align it.

Press the body closed around the coaxial cable and ensure the butyl sealant seals the joint between the earth kit body and the coaxial sheath.

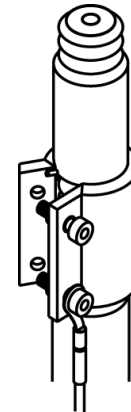

Step 3: Finish

Tighten the allen screw, to secure the earthing unit.

Affix the lug at the end of the earth wire to the earthing bar

Ensure there are no kinks or sharp bends in the earth cable

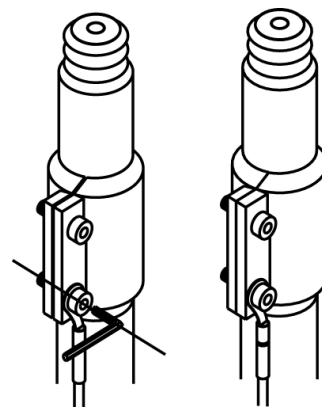



72 Browns Road, Kingston, TAS. 7050
AUSTRALIA

Telephone: +61 3 6229 7233
Facsimile: +61 3 6229 9245
E-mail: sales@novaris.com.au
Web site: www.novaris.com.au

No.15, 2nd Floor Jalan Tembaga SD 5/2
Sri Damansara Industrial Park,
52200 Kuala Lumpur, Malaysia
Telephone: 603-6273 1599
Facsimile: 603-6272 2599
E-mail: sales@novaris.com.my
Web site: www.novaris.com.au