

SLD - Signal Line Protectors



High Surge Current Signal Line Protectors

SLD Signal Line Protectors are designed to protect the most sensitive electronic equipment in lightning intense environments. So they are ideal for the protection of PLC's, fire and security systems, railway signalling and SCADA equipment.

Multistage Transient Protection

Models featuring multistage transient protection deliver greater levels of protection through a staged approach. The primary stage absorbs the majority of the surge energy. The remaining stages provide accurate clamping and a degree of redundancy.

Surge Current Fusing

Surge current fuses allow components to absorb maximum energy but in the event of a component failure the fuse will open to isolate the damaged component.

Safe Metal Enclosure

Novaris surge protection products are housed in safe, all metal enclosures. In the event of a prolonged overvoltage they will not catch fire or explode.

Diagram / Installation

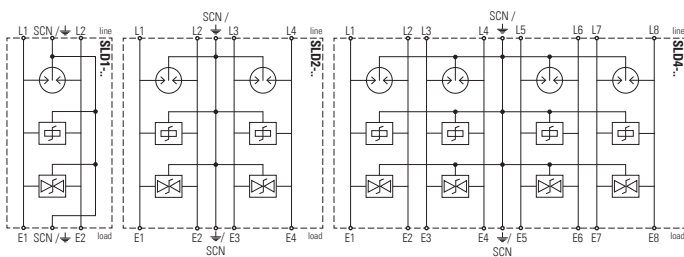

Dimensions

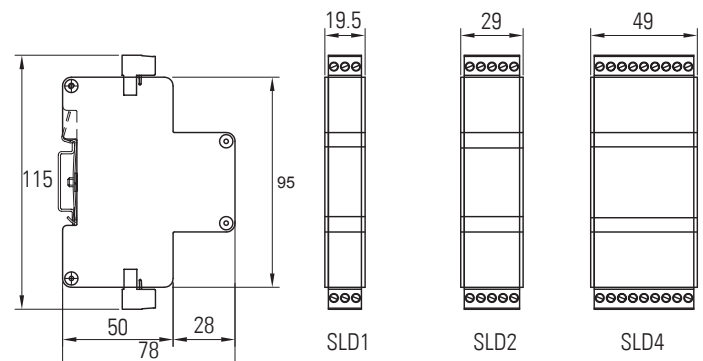

Ordering Information

	Signal Type		Options		
			Indirect Earthing	Max. load current: $I_L = 2 \text{ A}$	High frequency: $f_c = 10 \text{ MHz}$
SLDx-7v5	5 V digital	0 - 6 V analog	-EC90	-2	-H
SLDx-18	12 V digital	0 - 12 V analog	-EC90	-2	-H
SLDx-36	24 V digital	0 / 4 - 20 mA	-EC90	-2	-H
SLDx-68	48 V digital	-	-EC90	-2	-H
SLDx-485	RS 485	RS422	Standard	-2	-
SLDx-DH	RS232	Data Highway	Standard	-2	-
SLDx-PSTN	Public Switched Telephone Network		-EC90	-	-

Product Specifications

Model		SLDx-7v5	SLDx-18	SLDx-36	SLDx-68	SLDx-485	SLDx-DH	SLDx-PSTN
Electrical Specifications								
Connection Type		Series	Series	Series	Series	Series	Series	Series
Number of lines					x = 1 → 1 pair x = 2 → 2 pairs x = 4 → 4 pairs			
Modes of protection		Transverse and common mode						
Maximum continuous voltage (DC)	U_c	7 V	16 V	34 V	65 V	8 V	34 V	200 V
Maximum continuous voltage (AC)	U_c	5 V	11 V	24 V	46 V	6 V	24 V	–
Maximum discharge current (8/20 μ s)	I_{max}	10 kA per line (20 kA common mode)						
Maximum discharge current (10/350 μ s)	I_{imp}	1.25 kA per line (2.5 kA common mode)						
Impulse durability		C2 10 x 10 kA 8/20 μ s D1 2 x 2.5 kA 10/350 μ s						
Maximum load current	I_L	250 mA	250 mA	250 mA	250 mA	500 mA	500 mA	250 mA
L-L Voltage protection level @ 1 kV/ μ s	U_p	10 V	20 V	39 V	70 V	19 V	47 V	370 V
L-L Voltage protection level @ 3 kA 8/20 μ s	U_p	11 V	21 V	40 V	72 V	14 V	47 V	
L-L Voltage protection level @ 100 V/ s		8 V	18 V	36 V	68 V	10 V	38 V	360 V
L-PE Voltage protection level @ 1 kV/ μ s	U_p	10 V	20 V	39 V	70 V	19 V	47 V	370 V
L-PE Voltage protection level @ 3 kA 8/20 μ s	U_p	11 V	21 V	40 V	72 V	14 V	47 V	
L-PE Voltage protection level @ 100 V/ s		8 V	18 V	36 V	68 V	10 V	38 V	360 V
AC durability		5 x 1 s, 1 Arms	5 x 1 s, 1 Arms	5 x 1 s, 1 Arms	5 x 1 s, 1 Arms	5 x 1 s, 1 Arms	5 x 1 s, 1 Arms	5 x 1 s, 1 Arms
Overstressed fault mode		Mode 3 (open circuit)						
Response time	t_A	< 5 ns	< 5 ns	< 5 ns	< 5 ns	< 5 ns	< 5 ns	< 5 ns
Line resistance		8.2 Ω	8.2 Ω	8.2 Ω	8.2 Ω	3.9 Ω	3.9 Ω	8.2 Ω
Line inductance		33 μ H	33 μ H	33 μ H	33 μ H	< 1 μ H	< 1 μ H	< 1 μ H
L-L capacitance		11 nF	6 nF	5 nF	4 nF	19 pF	18 pF	148 pF
L-PE capacitance		11 nF	6 nF	5 nF	4 nF	25 pF	25 pF	158 pF
Insertion loss @ 150 Ω		< 0.5 dB (< 70 kHz)	< 0.5 dB (< 120 kHz)	< 0.5 dB (< 150 kHz)	< 0.5 dB (< 150 kHz)	< 0.5 dB (< 50 MHz)	< 0.5 dB (< 50 MHz)	< 0.5 dB (< 5 MHz)
3 dB Frequency @ 150 Ω	f_c	< 260 kHz	< 360 kHz	450 kHz	460 kHz	100 MHz	100 MHz	20 MHz
Mechanical Specifications								
Operating temperature		-40 to +85 °C						
Humidity Range		5 to 95% non-condensing						
Connection type / capacity		2.5 mm ² via pluggable connectors						
Terminal screw torque		0.5 Nm						
Environmental		IP 20/ Indoor						
Dimensional Drawing		see Dimensions						
Mounting		TS35 DIN rail						
Earthing		- Direct earth connection via DIN rail and screw terminals standard - 90 V isolation between DIN rail earth and shield with -EC90 option						
Enclosure / Colour		Metal / black						
Standards								
IEC 61643-21:2012		SPD connected to telecommunications and signalling networks - Cat C2, D1						
AS/NZS 1768:2007		Signalling/Telecommunications surge protection						
UL 1449 3 rd edition & UL 497B		Protectors for data communications and fire-alarm circuits						
ITU-T K.44: 2012		Resistibility tests for telecommunication equipment exposed to overvoltages and overcurrents						
AS/CA S008:2010		Requirements for Customer Cabling Products						
AS/NZS 4117:1999		Surge Protective Devices for Telecommunications Applications						
Shipping								
Weight		x = 1 → 250 g x = 2 → 300 g x = 4 → 400 g						
Customs Tariff		85363000	85363000	85363000	85363000	85363000	85363000	85363000

